

1. Test method

• **NEMA LD3 – 3.6**

The test measures the ability of the surface of high-pressure decorative laminate to maintain its color and surface finish when subjected to a high temperature.

• **Test sample**

The sample shall be at least 200 X 200 mm(8X8 inches)

• **Test procedure**

- a. Fill the heating vessel from ½ to 2/3 full with bath wax. Heat the wax unit it reaches a temperature of 185 °C (365 °F). Do not overheat as fire may result. Using the tongs, place the vessel on the test specimen and allow the remain in place for 20 minutes.
- b. A flat-bottom heating vessel in accordance with drawing on next page.
- c. Remove the vessel with the tongs and allow the specimen to stabilize at room temperature for a minimum of 24 hours.
- d. Clean the specimen with acetone to remove residual wax. Examine the conditioned test specimen by placing it, without pre-inspection, on a table and then view it at an eye-to-specimen distance of approximately 750 to 900mm (30 to 36 inches) and at an angle of approximately 45° to 75° from the horizontal plane of the table and viewed from all directions. Direct sunlight sources, which will accentuate or minimize the effect, shall be avoided.

2. Test result

| Blisters | Crazing | Whitening | Cracking | Dulling |
|-----------------|----------------|------------------|-----------------|----------------|
| No effect | No effect | No effect | No effect | No effect |

* No Effect : No change in color or surface finish

This Technical Bulletin is intended to provide guidelines for optimal fabrication, installation, and performance of LOTTE ADVANCED MATERIALS products mentioned. Though the information contained herein is deemed reliable, none of the contents--including but not limited to the instructions, techniques, graphics, and recommendations--is to be understood as implying legal liability of fitness for a specific purpose, any other type of warranty, or being complete or absolute in its range and nature of information.

Depending on the user's particular application, all necessary measures must be taken to verify and test the adequacy for such needs or application. Any information or recommendation herein is strictly for purposes of reference and as such, LOTTE ADVANCED MATERIALS assumes no responsibility for its suitability or accuracy or the use of such information for products other than LOTTE ADVANCED MATERIALS Staron® solid surfaces & Radianz® quartz surfaces.

Heating Vessel

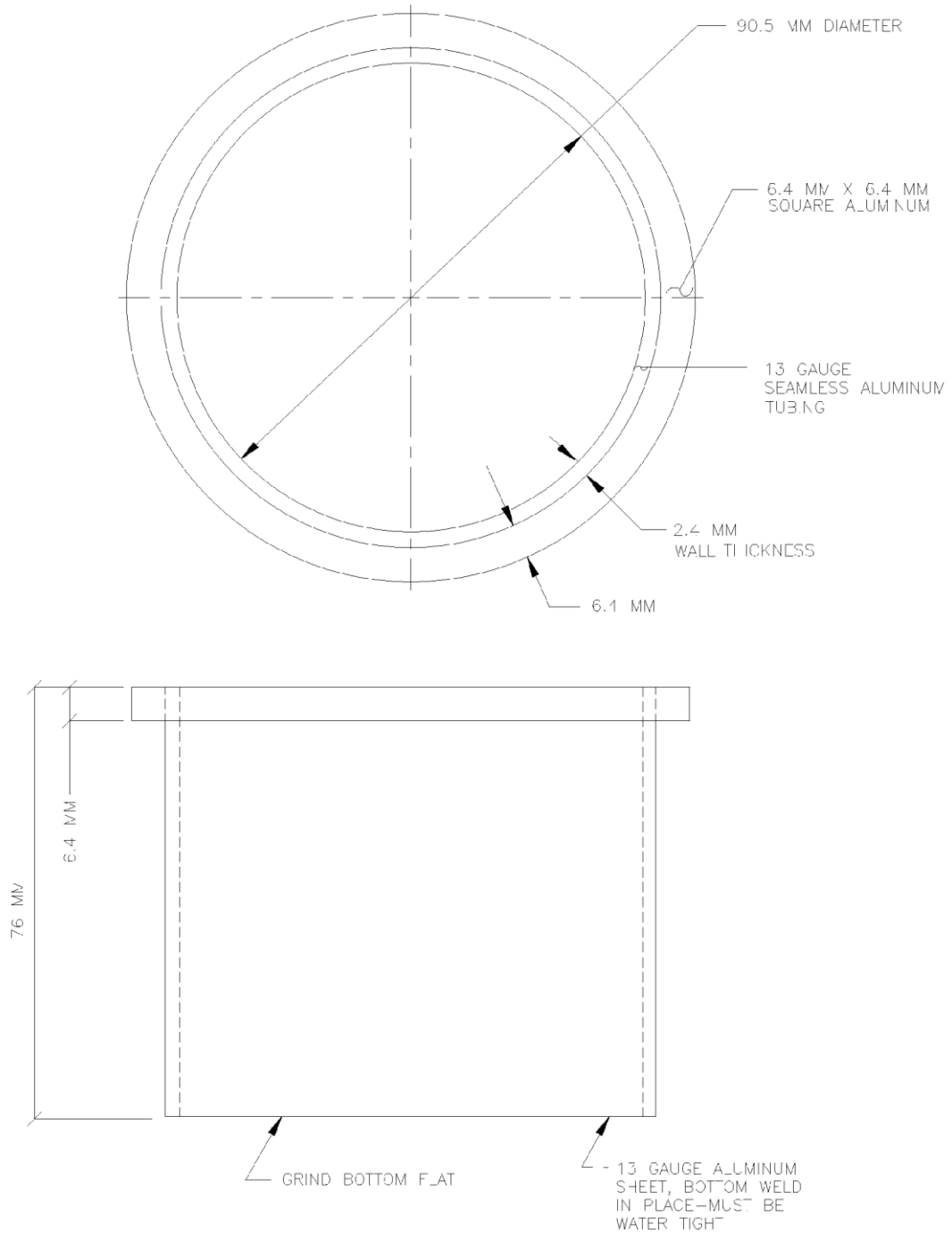

This Technical Bulletin is intended to provide guidelines for optimal fabrication, installation, and performance of LOTTE ADVANCED MATERIALS products mentioned. Though the information contained herein is deemed reliable, none of the contents—including but not limited to the instructions, techniques, graphics, and recommendations—is to be understood as implying legal liability of fitness for a specific purpose, any other type of warranty, or being complete or absolute in its range and nature of information.

Depending on the user's particular application, all necessary measures must be taken to verify and test the adequacy for such needs or application. Any information or recommendation herein is strictly for purposes of reference and as such, LOTTE ADVANCED MATERIALS assumes no responsibility for its suitability or accuracy or the use of such information for products other than LOTTE ADVANCED MATERIALS Staron[®] solid surfaces & Radianz[®] quartz surfaces.